



General characteristics

Rated power supply voltage		200...240VAC 50/60Hz
Rated output voltage	VAC	Three-phase 0...240VAC 0- 599Hz
Rated output current	A	1.7
Rated output power	kW	0.25
Rated output power	HP	0.33
EMC filter		Built-in EMC suppressor cat. C2
Communication port		None

Technical features

Input type		Single-phase
Rated mains voltage	VAC	200...240
Operating mains voltage range	VAC	170...264
Rated mains frequency	Hz	50/60
Operating mains frequency range	Hz	45...65
Rated mains current without mains choke		4
Rated mains current with mains choke		3.6
Output type		Three-phase
Output voltage range	VAC	0...240
Output frequency range	Hz	0...599
Current overload	%/s	150% for 60s, 200% for 3s
Power loss		15W
Brake chopper		No
Switching frequency		2...16kHz
Max motor cable length		
	Shielded	
		Without EMC category
		Category C2
		m
		m
		50
		15

Functions

Motor control modes	V/f linear, quadratic torque, sensorless vector control, ECO mode
---------------------	---

Speed reference signals	External potentiometer 0...10kΩ Voltage signals: 0...10VDC Current signals: 0/4...20mA Buttons on front keyboard Door-mount installation kit 15 preset speeds via digital inputs Motor potentiometer Fieldbus
3-wire control	Yes
S-shape curves	Yes
Slip compensation	Yes
Flying restart	Yes
Access to DC bus	No
DC braking	Yes
DC injection at start	Yes
PID control	Yes, with sleep and rinse function
Sequencer (programmable frequency/time cycles)	Yes
Preset speeds	Yes
Motorpotentiometer	Yes
Different parameter configuration sets	Yes
Parameters changeover function	Yes
Favorite parameters menu	Yes
Autotuning	No
Safe torque Off (STO) safety function	No
PTC probe input	No
Protections	Overcurrent Output short circuit and earth/ground leakage Overvoltage Undervoltage Phase loss Motor heat overload (i2t) Overspeed Speed reverse
Special funct.	Multi-pump PID control (1 main pump frequency regulated + 2 auxiliary pumps activated in direct mode in case of necessity)

Input and Output

Number of digital input	Nr.	5
Digital input type		Selectable PNP or NPN logic
Number of digital output	Nr.	2
Digital output arrangement		1 relay output with changeover contact (C/O-SPDT) + 1 digital output
Output contacts ratings		Relay output: 3A 250VAC Digital output: 100mA max 30VDC
Number of analog input	Nr.	2
Analog input type		Analog input 1: configurable 0/2...10VDC, 0...5VDC, 0/4...20mA Analog input 2: configurable 0/2...10VDC or 0...5VDC
Number of analog output	Nr.	1
Analog output type		configurable as 0...10VDC, 0...5VDC, 2...10VDC, 0/4...20mA

Ambient conditions

Temperature

Operating temperature

min	°C	-10
max	°C	+55
Current derating		2.5%/°C over 40°C

Storage temperature

min	°C	-25
max	°C	+60

Relative humidity	%	5...95% (with no condensing)
Max altitude	m	4000m (over 1000m derate the rated current by 5%/1000m)
Maximum Pollution degree		2
Overvoltage category		III up to 2000m altitude (II above 2000m)

Housing

Installation position		Vertical
IP degree of protection		IP20
Dimensions (W x H x D)	mm	60 x 183 x 130
Weight	Kg	0.75

Dimensions

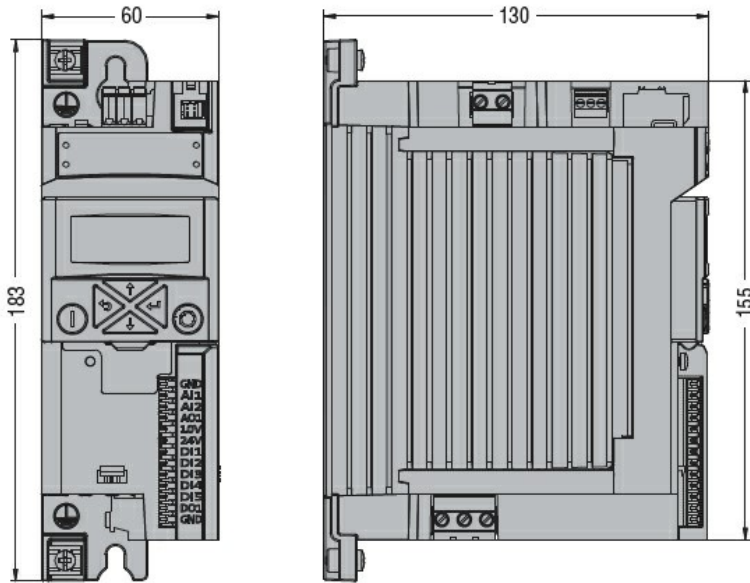

Wiring diagrams

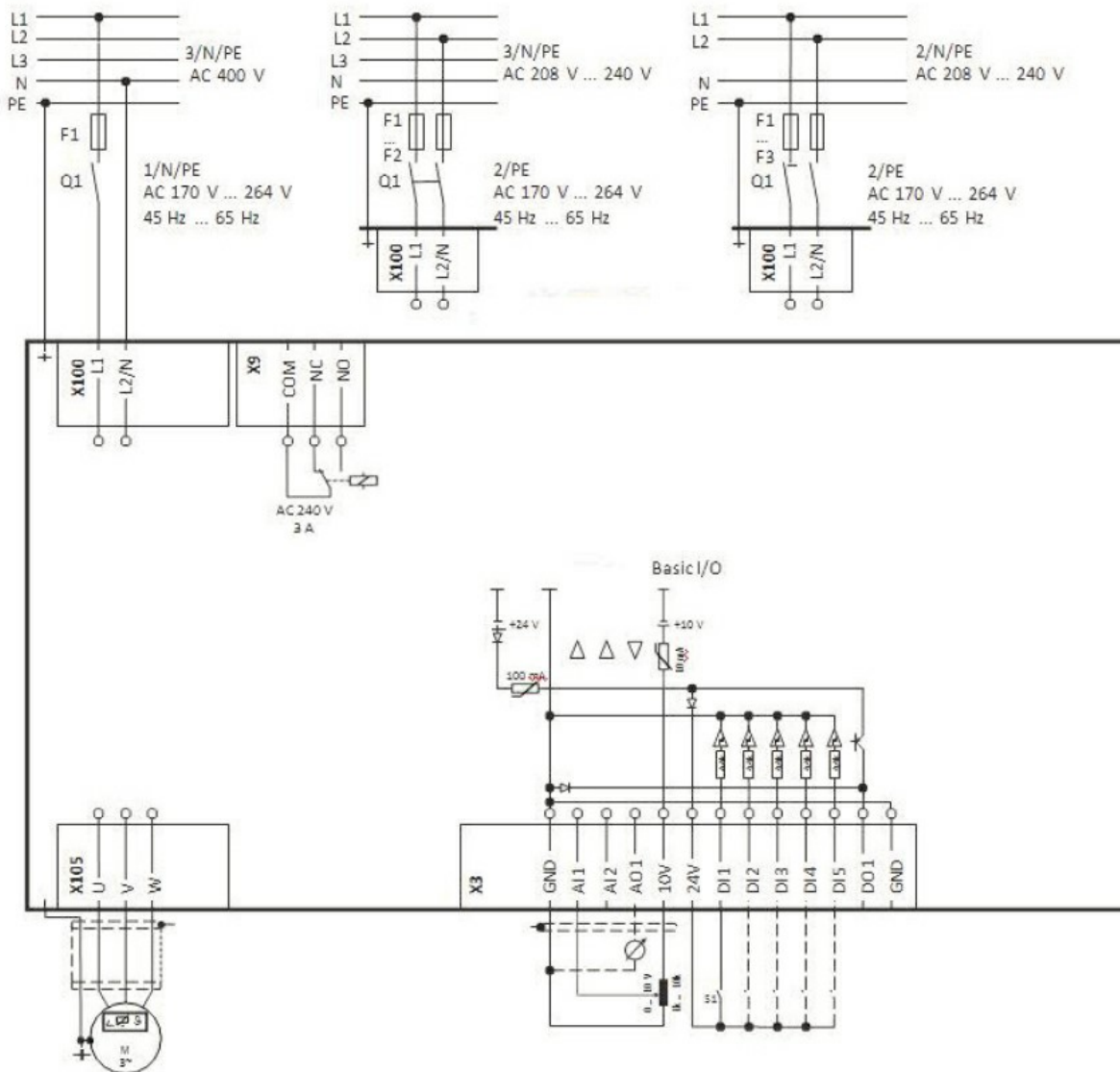

Certifications and compliance

Compliance

CSA 22.2 No. 274

EN 61800-5-1

UL61800-5-1

Certificates

cULus

EAC

RCM

ETIM classification

ETIM 8.0

EC001857 -
Frequency
converter =< 1 kV