

**RJ45G1 R1D 3.3E4GY/GY RL****Weidmüller Interface GmbH & Co. KG**

Klingenbergstraße 26

D-32758 Detmold

Germany

www.weidmueller.com



Les connecteurs d'émetteur RJ45 (magnétique) pour applications gigabit (1000 base-T) avec compensation intégrée compensent activement les couplages inductifs et capacitifs et gagnent de la place sur le circuit imprimé.

La gamme de produit comprend les conceptions suivantes :

- 90°, couché (horizontal) et 180°, debout (vertical)
- verrouillage / déverrouillage
- Systèmes de soudure THT, THR ou SMD
- Large gamme de formes, également avec des LED intégrées et des languettes de contact blindage
- Vitesses de transmission jusqu'à 1 Gbit/s
- Version emballée sur plateau (TY) ou en rouleau (Tape-on-Reel, RL)
- Compatible avec le connecteur modulaire RJ45, selon ANSI / TIA-1096-A et CEI 60603
- Rigidité diélectrique  $\geq 1500$  V AC RMS (2250 V AC valeur crête) selon IEEE 802.3
- Rigidité diélectrique  $\geq 1500$  V AC (valeur crête) ou  $\geq 1500$  V DC selon CEI 60603
- Conformité avec les exigences de IEEE 802.3 (1000Base-T, 1 Gbit/s, IEEE 802.3ab ou 100Base-Tx, 100 Mbit/s, IEEE 802.3u)

Propriétés et avantages :

- Plage de température étendue de  $-40$  °C à  $+85$  °C pour une puissance maximale

- Couche d'or renforcée ( $30\mu$ ) pour une protection contre la corrosion améliorée
- Une distance minimale de 0,3 mm garantit une soudure parfaite

**Informations générales de commande**

Version	Connecteur pour circuit imprimé, Transformateur prises RJ45, Raccordement soudé THT/THR, 90°, Option de verrouillage: bas, Nombre de pôles: 8, Tape
Référence	<a href="#">2638860000</a>
Type	RJ45G1 R1D 3.3E4GY/GY RL
GTIN (EAN)	4050118657098
Qté.	200 pièce(s)
Emballage	Tape

Date de création 7 novembre 2022 13:44:49 CET

Niveau du catalogue 25.10.2022 / Toutes modifications techniques réservées

**RJ45G1 R1D 3.3E4GY/GY RL****Weidmüller Interface GmbH & Co. KG**

Klingenbergstraße 26

D-32758 Detmold

Germany

www.weidmueller.com

**Caractéristiques techniques****Dimensions et poids**

Poids net 0,025 g

**Classifications**

ETIM 6.0	EC002637	ETIM 7.0	EC002637
ETIM 8.0	EC002637	ECLASS 9.0	27-44-04-02
ECLASS 9.1	27-44-04-02	ECLASS 10.0	27-44-04-02
ECLASS 11.0	27-46-02-01	ECLASS 12.0	27-46-02-01

**Propriétés électriques**

Courant nominal	1,5 A	Rigidité diélectrique, contact - blindage	1500 V DC
Rigidité diélectrique, contact - contact	1000 V DC		

**Caractéristiques du système**

Angle de sortie	90°	Cycles d'enfichage	750
Degré de protection	IP20	Famille de produits	Données OMNIMATE - Prise transformateur RJ45
Longueur du picot à souder (l)	3,3 mm	Montage sur le circuit imprimé	Raccordement soudé THT/ THR
Nombre de pôles	8	Option de verrouillage	bas
Pas en mm (P)	1,27 mm	Pas en pouces (P)	0,05 inch
Système de soudure	Soudure par refusion, Soudure manuelle, Soudure à la vague	Tolérance sur la position du picot à souder	± 0,1 mm
Type de raccordement	Raccordement soudé		

**Emballage**

Emballage	Tape	Longueur VPE	0 m
Largeur VPE	0 m	Hauteur VPE	0 m

**Agréments**

ROHS Conforme

**Téléchargements**

Agrément/Certificat/Document de conformité	<a href="#">Certificate of Compliance</a>
Données techniques	<a href="#">CAD data – STEP</a>
Catalogue	<a href="#">Catalogues in PDF-format</a>

**RJ45G1 R1D 3.3E4GY/GY RL**

**Weidmüller Interface GmbH & Co. KG**  
 Klingenbergstraße 26  
 D-32758 Detmold  
 Germany

www.weidmueller.com

**Dessins**

**Circuit**

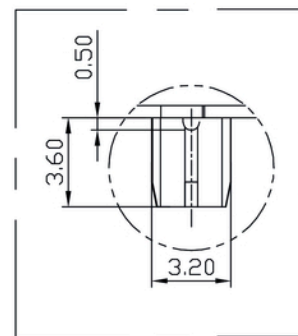
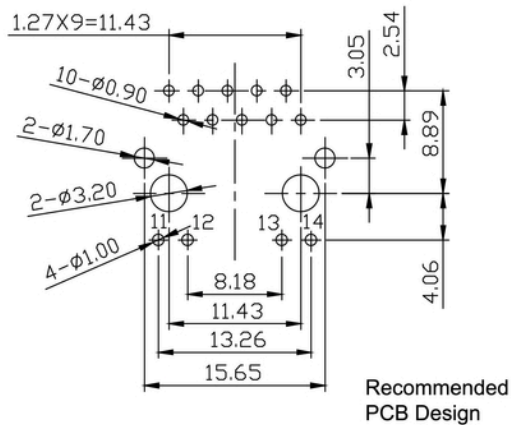
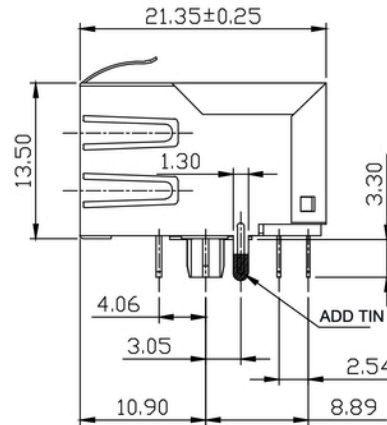
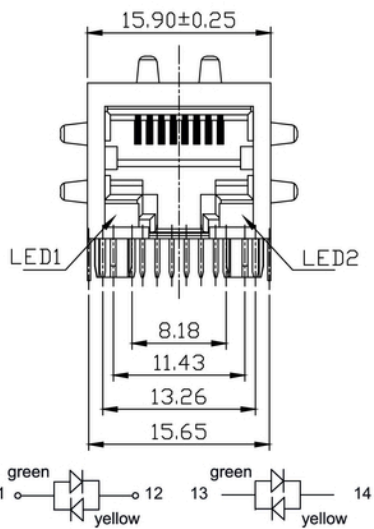
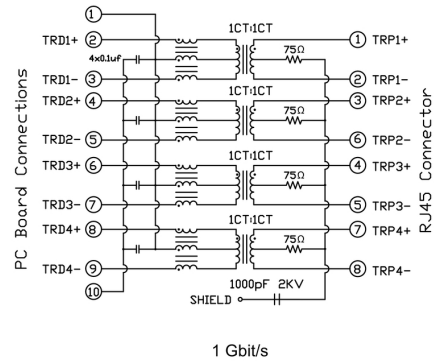
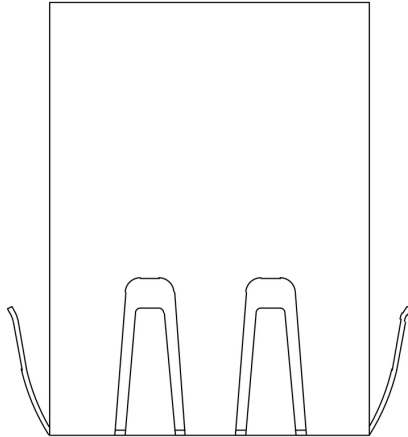

DETAIL "C"  
 SCALE 2:1

**RJ45G1 R1D 3.3E4GY/GY RL**

**Weidmüller Interface GmbH & Co. KG**  
 Klingenbergstraße 26  
 D-32758 Detmold  
 Germany

www.weidmueller.com

**Dessins**

**schématique**

Code	Description	Options
RJ45		
G1		
R		
1		
U		
3.2		
E		
4		
GY/GY		
TY		
<b>RJ45G1 R1U 3.2E4GY/GY TY</b>		
<b>Packaging</b>	<b>TY</b>	Tray in box (manual assembly)
	<b>RL</b>	Tape on Reel (automated assembly)
<b>LED</b>	<b>Y/G</b>	Yellow/Green
	<b>G/Y</b>	Green/Yellow (standard)
	<b>GY/GY</b>	Green-Yellow/Green-Yellow
	<b>O/G</b>	Orange/Green
	<b>R/O</b>	Red/Orange
	<b>...</b>	... (further combinations possible)
	<b>N</b>	without LED
<b>Contact surface thickness</b>	<b>4</b>	1 = 3µ", 2 = 6µ", 3 = 15µ", 4 = 30µ", 5 = 50µ"
<b>EMI tabs (ground fingers)</b>	<b>E</b>	E = with EMI tabs
	<b>N</b>	N = without EMI tabs
<b>Solder Pin length</b>	<b>3.2</b>	3.2 mm
	<b>1.6</b>	1.6 mm
	<b>D</b>	SMD
<b>Direction, latch style</b>	<b>U</b>	Horizontal (90°, side entry), latch up
	<b>D</b>	Horizontal (90°, side entry), latch down
	<b>V</b>	Vertical (180°, top entry)
	<b>Y</b>	Diagonal (45°), latch up
<b>Number of Ports</b>	<b>1</b>	1 Port
	<b>12; 14; ...</b>	multi ports side by side, Multiport
	<b>21; 41; ...</b>	multi ports about each other, Multilevel
<b>Assembly on PCB</b>	<b>R</b>	Through Hole Reflow - THR
	<b>S</b>	Soldering process: Wave or Reflow soldering
	<b>S</b>	Surface Mount Technology - SMT
	<b>T</b>	Soldering process: Reflow soldering
	<b>T</b>	Through Hole Technology - THT
	<b>T</b>	Soldering process: Wave
<b>Performance Category</b>	<b>C5</b>	Category 5
	<b>C6</b>	Category 6
	<b>C6A</b>	Category 6A
	<b>C5e</b>	Category 5e
	<b>M</b>	10/100 Mbit
	<b>G1</b>	10/100/1000 Mbit
	<b>G10</b>	10 Gbit
	<b>U</b>	Unshielded
	<b>MP</b>	10/100 Mbit with POE
	<b>MP+</b>	10/100 Mbit with POE+

Clé de codage des modèles

## Recommended wave soldering profiles

**Weidmüller Interface GmbH & Co. KG**  
 Klingenbergstraße 16  
 D-32758 Detmold  
 Germany  
 Fon: +49 5231 14-0  
 Fax: +49 5231 14-292083  
 www.weidmueller.com

### Single Wave:



### Double Wave:



### Wave soldering profiles

Wired connection elements should be processed in accordance with the DIN EN 61760-1 standard. We have included two recommendations for practical wave soldering profiles, with which Weidmüller PCB terminals and connectors are qualified.

When choosing a suitable profile for your application, the following factors also need to be considered:

- PCB thickness
- Proportion of Cu in the layers
- Single/double-sided assembly
- Product range
- Heating and cooling rates

The single and double wave profiles each indicate the recommended operating range, including the maximum soldering temperature of 260°C. In practice, the maximum soldering temperature is quite often well below the above maximum profile.

## Recommended reflow soldering profile

**Weidmüller Interface GmbH & Co. KG**  
 Klingenbergstraße 16  
 D-32758 Detmold  
 Germany  
 Fon: +49 5231 14-0  
 Fax: +49 5231 14-292083  
 www.weidmueller.com



### Reflow soldering profile

The perfect soldering profile for SMT Surface Mount Technology is one the most exiting question in SMT production. But there are more than one correct answer: The diagram of temperature-on-time is related to processing features of solder paste and to maximum load of components.

We have to consider the following parameters:

- Time for pre heating
- Maximum temperature
- Time above melting point
- Time for cooling
- Maximum heating rate
- Maximum cooling rate

We recommend a typical solder profile with associated process limits. With preheating components and board are prepared smoothly for the solder phase. Heating rate is typically  $\leq +3\text{K/s}$ . In parallel the solder paste is ‚activated‘. The time above melting point of 217°C the paste gets liquid and components and boards begin to connect. The maximum temperature of 245°C to 254°C should stay between 10 and 40 seconds. In the cooling phase at  $\geq -6\text{K/s}$  solder is cured. Board and components cool down while avoiding cold cracks.